

Application Note

CS4201/CS4202 HEADPHONE JACK SENSING USING GPIO

1. INTRODUCTION

This application note describes how to implement headphone jack sensing using General Purpose Input/Output (GPIO) pins on the CS4201 and CS4202 audio codecs.

2. HEADPHONE JACK SENSE

The CS4201 and CS4202 codecs use different GPIO pins to implement headphone jack sensing. The audio driver will mute or unmute the Line Outputs based on the state of GPIO1 (pin 44) on the CS4201, or GPIO2 (pin 32) on the CS4202.

Figure 1 below shows the applicable section of a two channel CS4201/CS4202 dual design with headphone jack sensing. The use of an insulated stereo 3.5mm jack ensures that audio signals do not affect the state of the GPIO sensing pin. When headphones are not inserted in the connector, the GPIO pin is pulled to DGND by the insulated wiper

and the Line Outs are unmuted. When headphones are inserted, the GPIO pin is pulled to +3.3V and the Line Outputs are muted. The CS4202 codec can accommodate simultaneous headphone jack sensing and six channel audio configurations. However, these are mutually exclusive functions on the CS4201. For information on using headphone jack sensing on CS4202 six channel applications, see the CRD4202-1 datasheet.

The CS4202 requires a PW4046 (or newer) Windows WDM audio driver. This driver is compatible with the CS4201 and supports Windows 98se, ME, 2000, and XP.

3. TYPICAL APPLICATION

Figures 2, 3, and 4 in the following schematics show a typical CS4201/CS4202 two channel audio motherboard application with headphone jack sense.

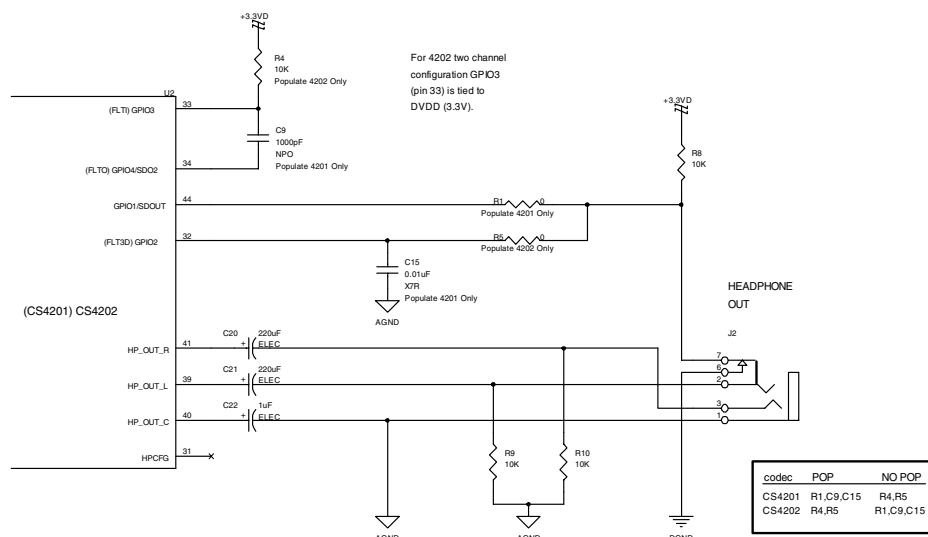

Figure 1. CS4201/CS4202 Headphone Jack Sensing Design

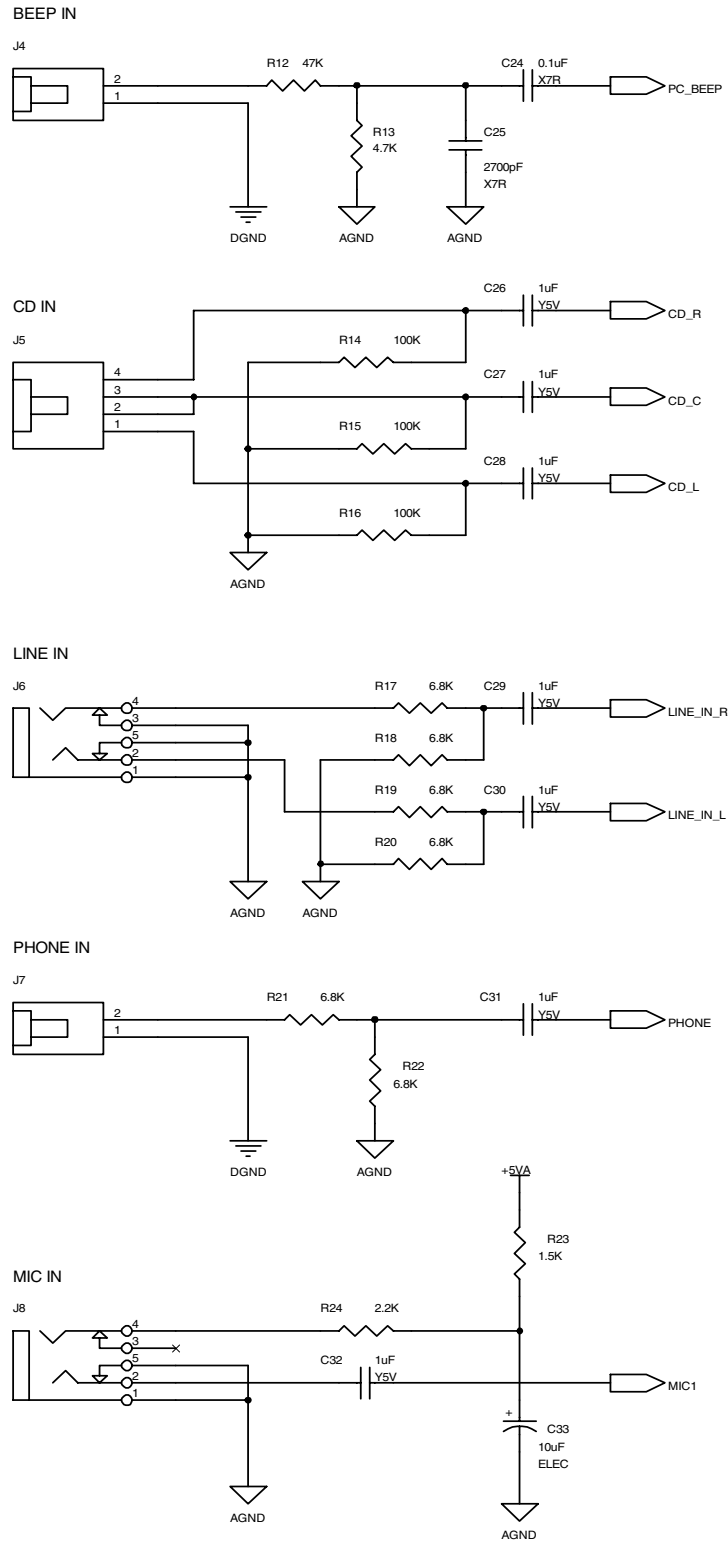

Figure 2. Audio Inputs

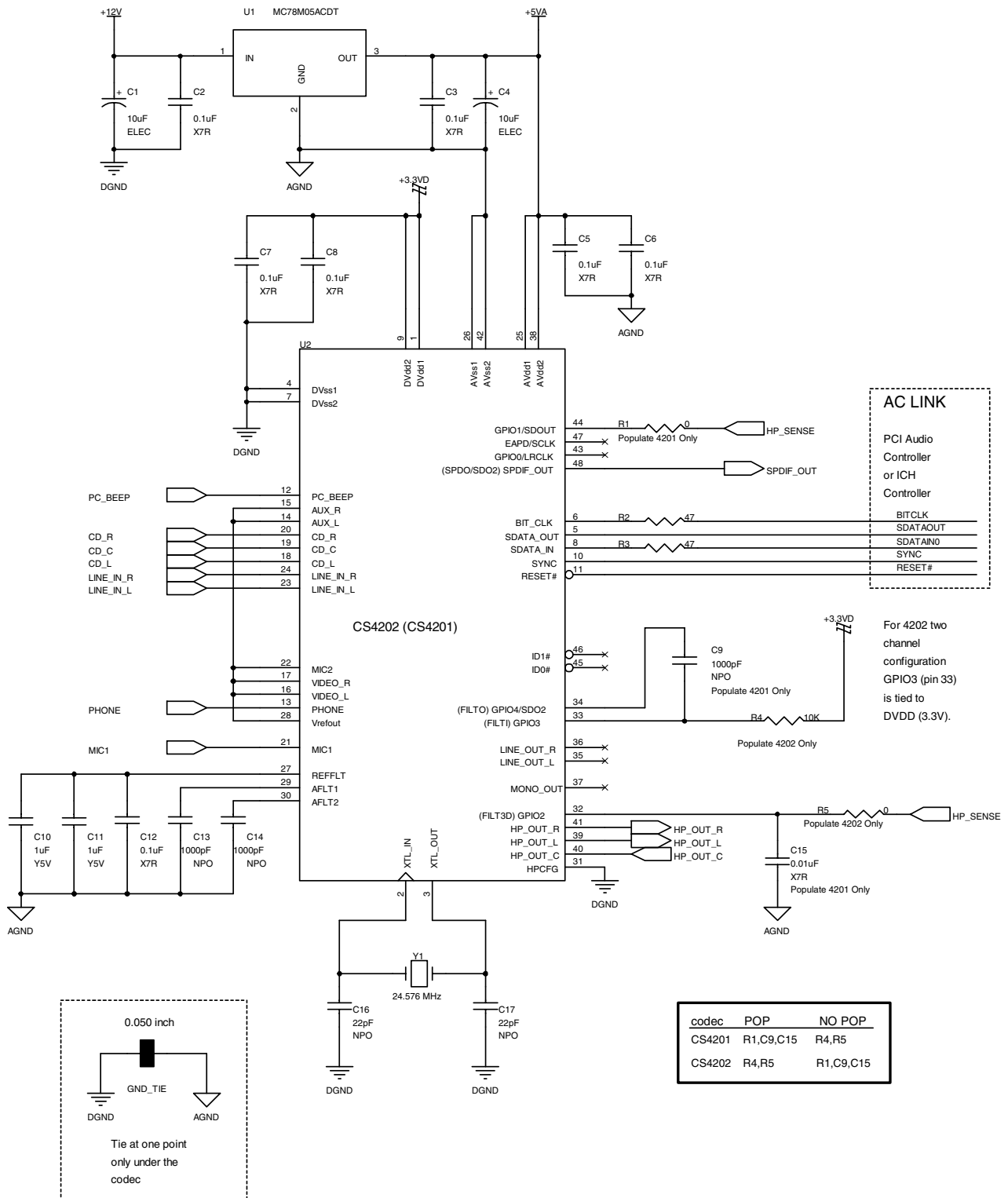

Figure 3. CS4202

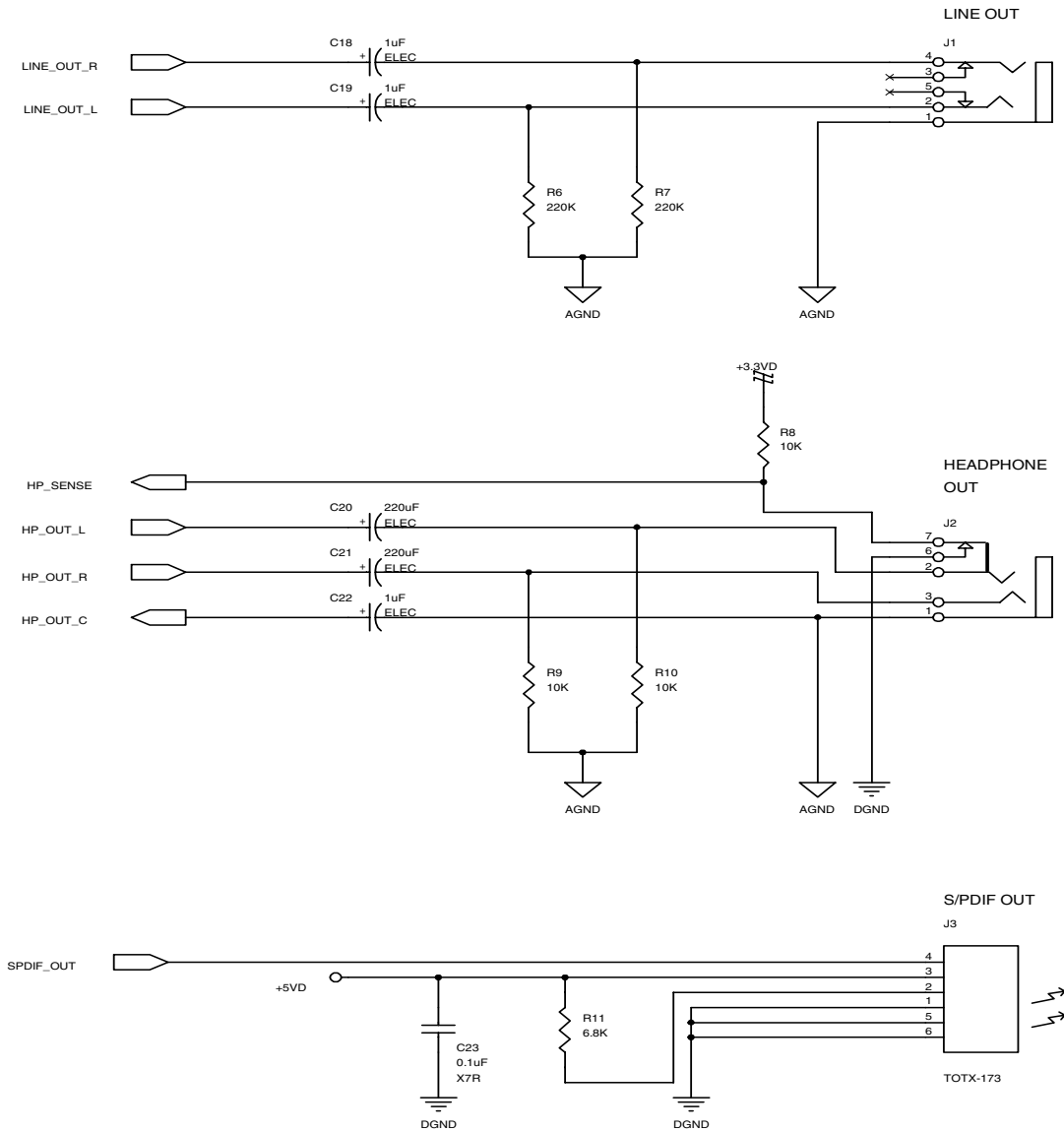

Figure 4. Analog and Digital Audio Outputs

• **Notes** •



CIRRUS LOGIC[®]